

Chroma Systems Solutions, Inc.

# Line Leakage Measurement And Human Body Equivalent Circuits

**19032 Safety Analyzer**

Keywords: Line Leakage Current, Human Body Equivalent Circuit Models,  
Electrical Safety of Medical Devices

Title:

# Line Leakage Measurement And Human Body Equivalent Circuits

Product Family: **19032 Safety Analyzer**

---

## Scope

Line Leakage measurement is perhaps one of the most important electrical safety tests for medical products today. It is one of the most stringent yet telling parameters of possible patient/operator danger. What can a little current leak do? After all 'it's the volts that'll kill you not the amps', isn't that what they said in Engineering 101? Let's look at the various line leakage tests and circuit models to find out just how wrong that myth can be.

Electric shock results from an electric current flowing through the human body and it doesn't take much especially with weakened immune systems of patients. This is why leakage current measurement of electrical medical products is so critical. As defined in NFPA 99, Health Care Facilities, just three conditions occurring simultaneously can shock the patient or operator.

- a. One part of the body is in contact with a conductive surface
- b. A different part of the same body is in contact with a second conductive surface
- c. A voltage source that will drive current through the body between those two points of contact.

## Example

Figure 1 illustrates eight separate conditions should be analyzed when evaluating the electrical safety of medical devices.

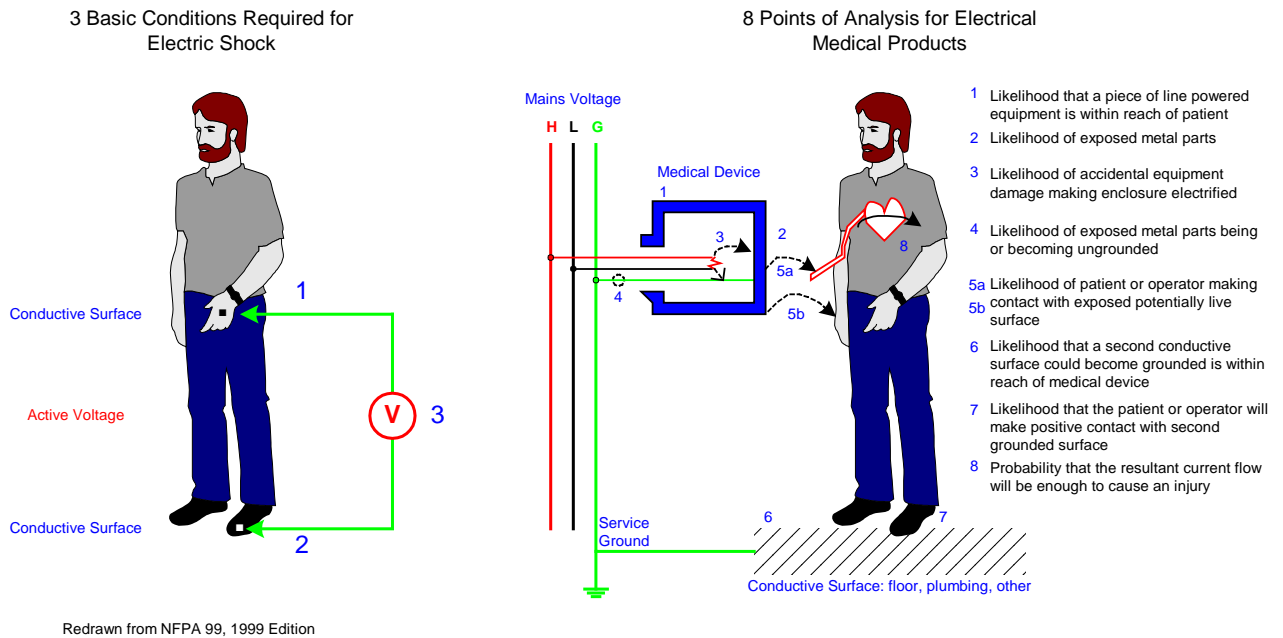

Figure 1: Electrical Shock & Analysis Points for Medical Devices

## Line Leakage Current Definition

A line leakage current test simulates the effect of a person touching exposed metal parts of a product and detects whether or not the leakage current that would flow through that person’s body remains below a safe level. Safe Levels are defined by specific standards such as IEC60601-1, UL 2601-1, and ANSI/AAMI ES1-1993 among others. Line leakage tests are conducted by applying power to the product being tested then measuring the leakage current from any exposed metal on the chassis of the product under various fault conditions, such as ‘no ground’. A special circuit is used to simulate the impedance of the human body. Before we get to the circuit models let’s clearly define various leakage current tests and the pertinent electrical safety test (EST) terminology.

**Leakage current:** the measure of the residual flow of current through insulation after a high voltage has been applied for a period of time.

**Earth Leakage Current:** the current flowing back through the ground conductor on the power cord. It is measured by opening the ground conductor inserting a circuit with simulated impedance of the human body and then measuring the voltage across part of the circuit with a true RMS voltmeter.

**Enclosure Leakage Current:** this test measures the current that flows through the (simulated) human body if the enclosure of the product under test were to be touched.

**Applied Part Leakage Current:** this test measures the current that would flow from or to applied parts and between parts of the product such as sensor and patient leads. Also known as **Patient Leakage Current**.

**Protective Earth:** the ground conductor in the power cord or ground wire used to protectively (Earth) ground the product under test. Also known as **Chassis Ground**.

**Functional Earth:** the conductor on the product under test not intended for chassis ground.

**Mains Voltage:** the supply or line voltage (115V AC or 230V AC).

**Applied Part:** any part of the product under test that intentionally comes in contact with the patient/operator.

**Accessible Part:** any part of the product under test that can be touched by the operator/patient without the use of a tool.

**Patient Lead:** any deliberate electrical connection that can carry current between an appliance and a patient.

**Enclosure:** is the outer case of the product under test.

**Single Faults:** an electrical condition that could happen and cause a problem. IEC60601-1 tests: Open Protective Ground, Open Neutral, Mains voltage on output jacks, Mains voltage on applied part, Shorted insulation, Open external power supply ground and Open external power supply neutral.

**Normal Conditions:** electrical conditions that occur on a daily basis and not considered a detriment. IEC60601-1 tests: Reversed AC line, Grounded functional earth (FE), Grounded patient lead, Grounded isolated metal parts, Reversed mains voltage polarity on output jacks, Reversed mains voltage polarity on applied part and External power supply (FE) grounded.

## Human Body Equivalent Circuit Models

There are 5 basic Human Body Equivalent Circuit models defined in different safety testing standards and therefore named for some of those standards as illustrated in Figure 2. These circuits simulate the impedance of the human body and compensate for the change of physiological response of the body with frequency. The UL 1950 model shown is applicable for frequencies up to 1MHz. Refer to the standard you are required to test to for frequency specifications.

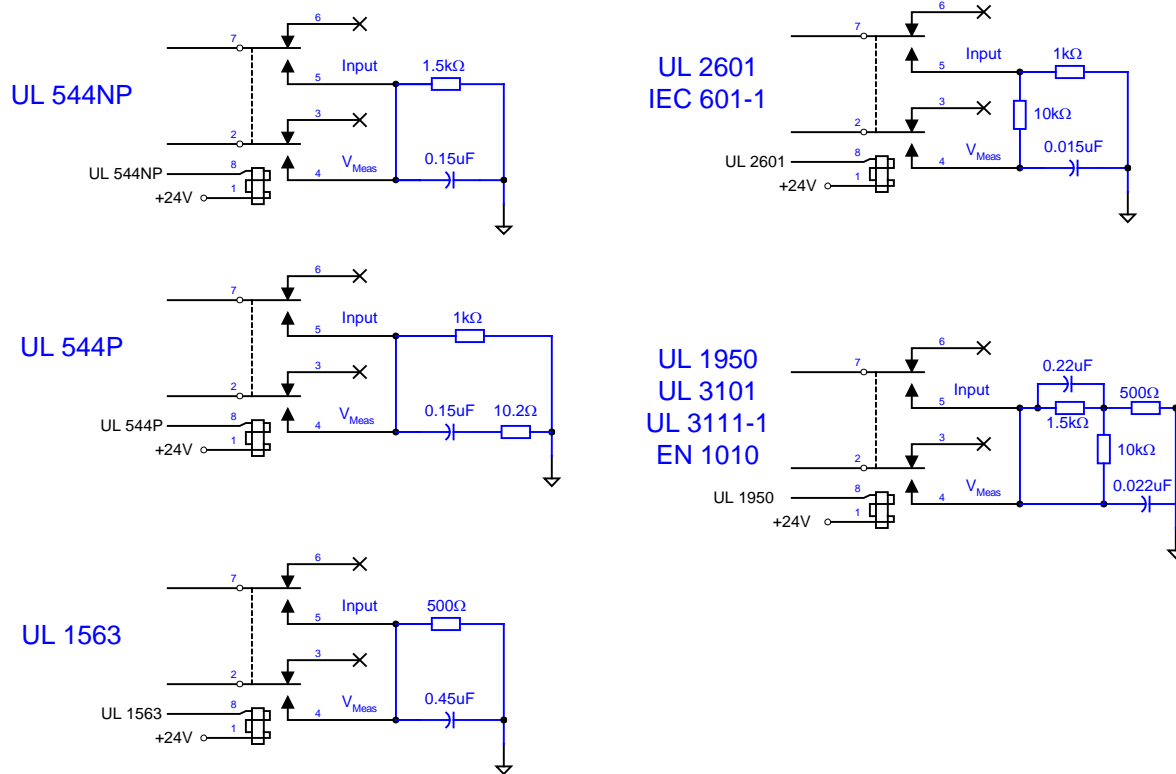

Figure 2: Five Basic Human Body Equivalent Circuit Models

In addition to AC/DC hipot, insulation resistance and power consumption measurements, the Chroma 19032 Production Safety Analyzer for Electronic Medical Devices is capable of performing line leakage current measurements for the five device models shown in Figure 2.

For complete product specifications on the 19032 Production Safety Analyzer or any of Chroma products, visit us at [www.Chromausa.com](http://www.Chromausa.com). Do you have an application specific testing need? Call us at 978-461-2100 for east coast, 949-600-6400 for west coast or email your questions to [sales@chromausa.com](mailto:sales@chromausa.com).